

High Speed Next Generation Networks  
and  
the Role of the Semiconductor Industry  
by  
Dr. M. Kalam

[mkalam@utdallas.edu](mailto:mkalam@utdallas.edu)

972-883-4623

Department Of Electrical Engineering  
THE UNIVERSITY OF TEXAS AT DALLAS  
P.O. BOX 830688 MS EC33 RICHARDSON, TEXAS  
75083-0688



# Networks

## Definition of Networks:

- Collection of interconnected intelligent devices
- Could mean smaller segments of a big network
- Beware that networks could mean many things to many people

## Purpose:

- It exists because business demands it
- Business needs applications that need networks

## Current Networking Infrastructures:

- Telephone networks
- Data networks (Internet & Intranet)
- Control and Management networks for manufacturing plants, power grids, oil and gas pipelines

## Convergent Networks

- Single infrastructure for both Telephone and data
- Resulting in mergers and shake up in the industry

## NGN – Next Generation Convergent Networks

- High speed, high bandwidth and always available networks for both voice, video and data communications

# Current Status – Convergent and A Silent Revolution in Communications Industry

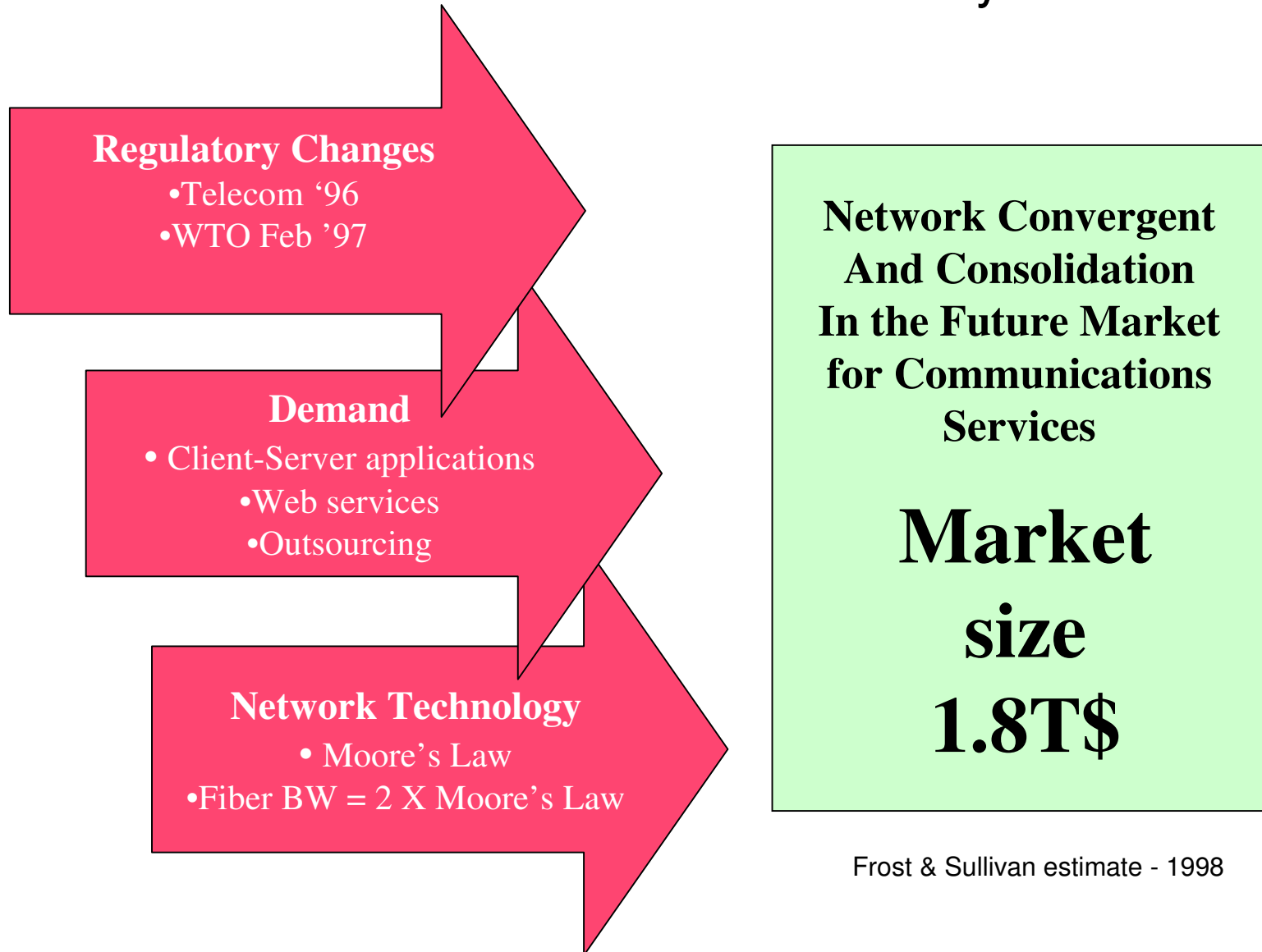

# Voice and Data Growth

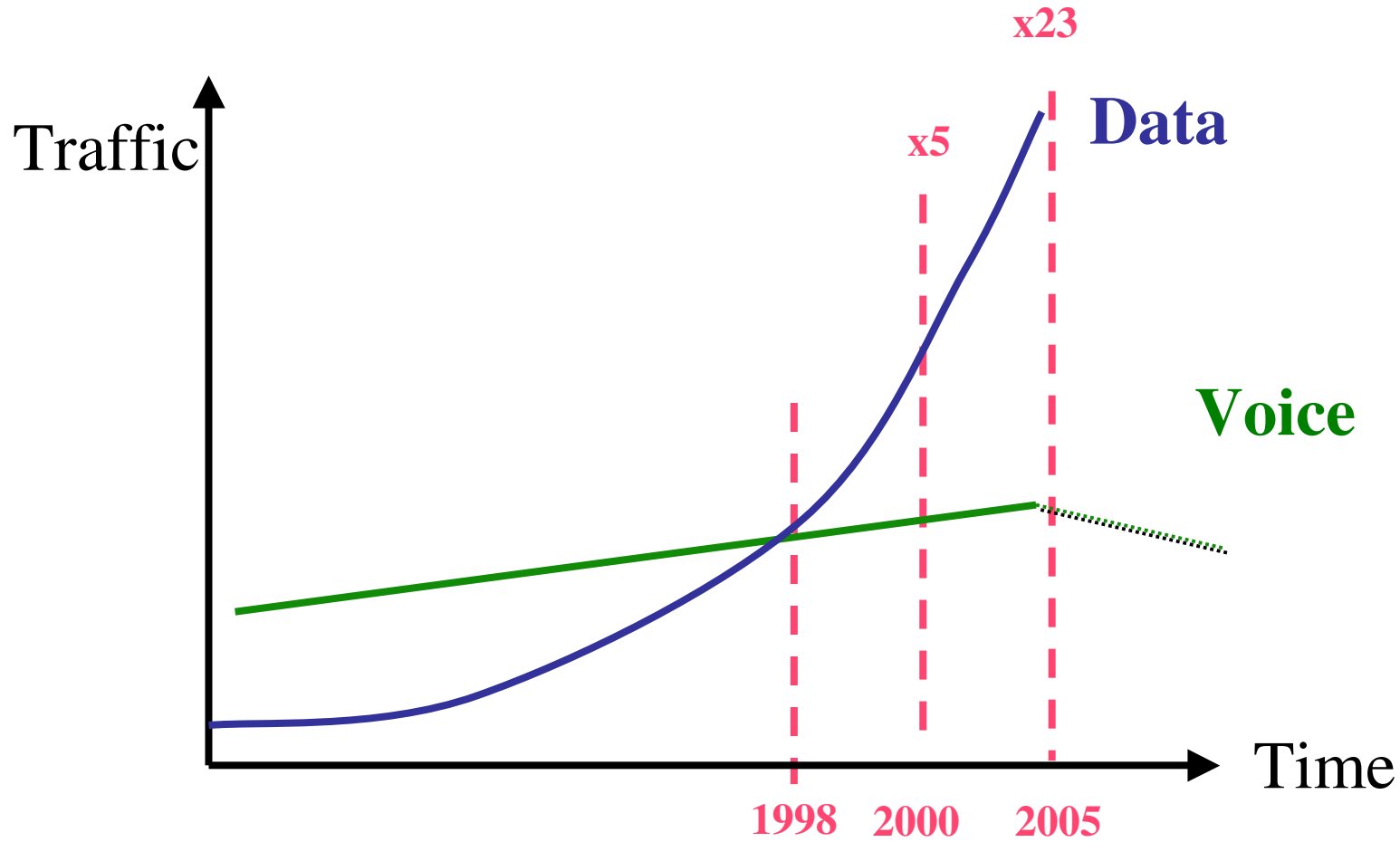

Frost & Sullivan estimate - 1998

# Historical Background

## Centralized Processing:

- All applications are run in one central place by a processor
- IBM Systems Networking Architecture
- Unix based systems
- Use Dumb Terminals as access devices

## Distributed Processing:

- Client/Server
- Peer-to-Peer
- Use intelligent devices to access the network

## Dumb Terminals Screen definitions

- SNA 3270 and 5250 (IBM standard)
- VT 100, 200 and 300 (DEC standard)

## Intelligent Terminals screen definitions are based on Operating Systems

- Microsoft Windows GUI
- Apple Mac GUI
- Linux GUI

# Legacy Telephone Network – PSTN (130 yr old)

The generic component of the public switching telecommunication network is divided into:

**Subscribers/ Local loop** - (connects subscribers to the network)

**Exchange** - (switching centers, Central Office or End Office)

**Trunks** - (connection between exchanges carry multiple voice channels using FDM or STDM)

[FDM – Frequency Division multiplexing, STDM – Statistical Time Division Multiplexing]

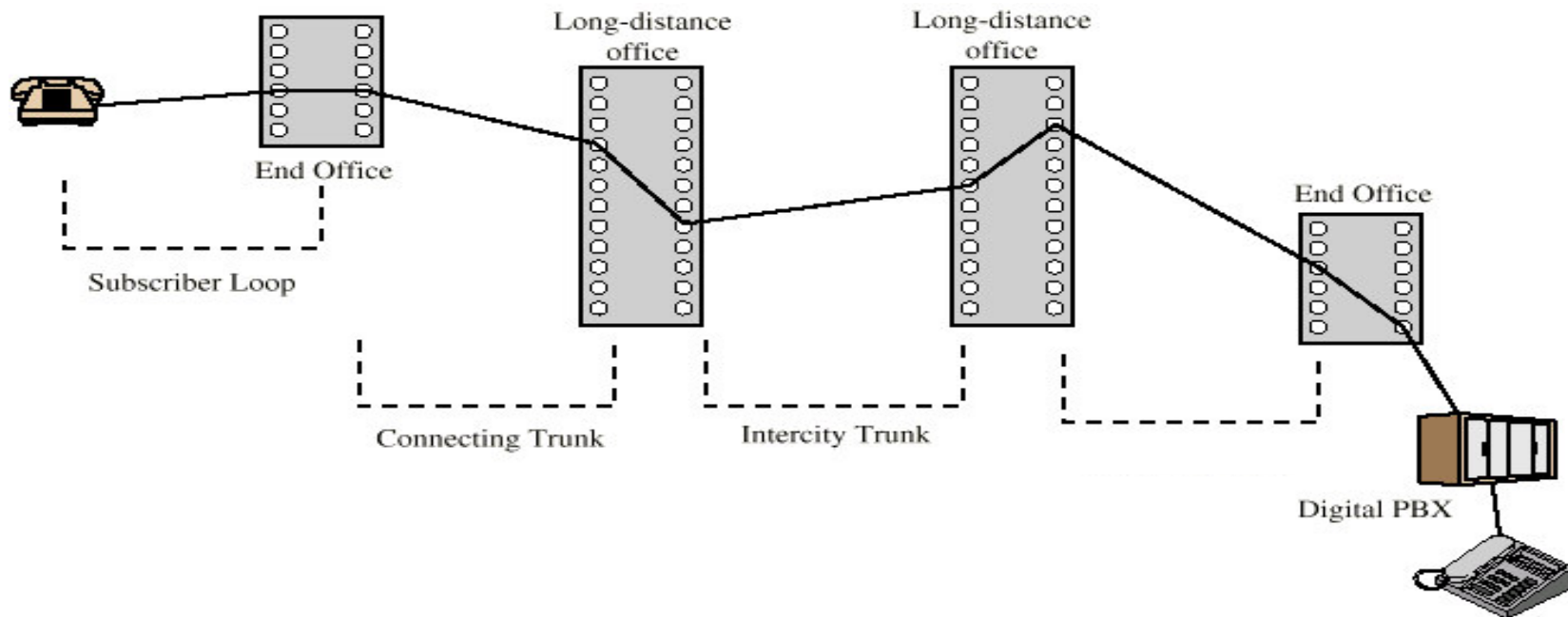

# Data Network

---

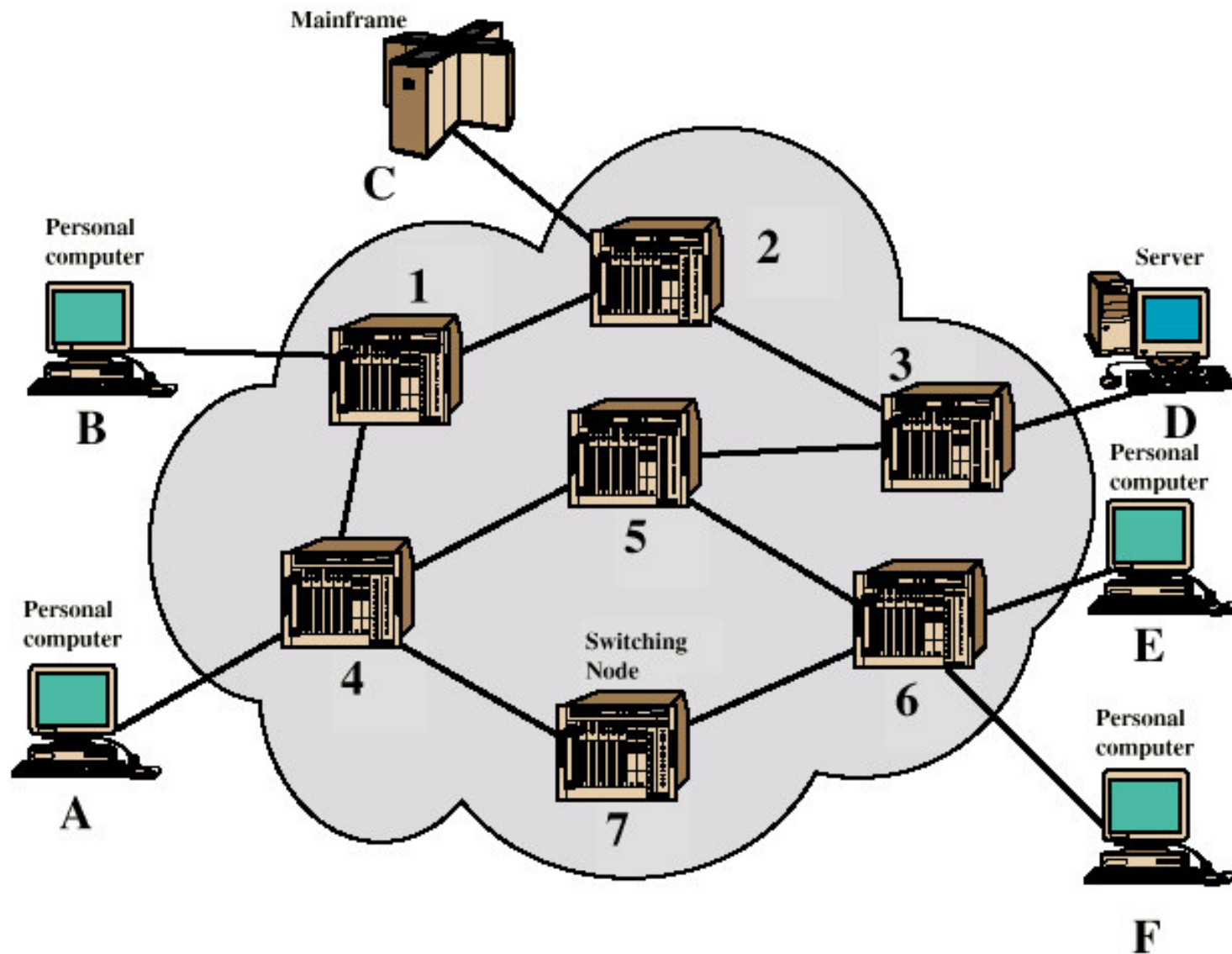

# Data Networking Infrastructure

Relatively more complex than PSTN since it may include

- SNA (Systems Networking Architecture by IBM)
- LAN with Wireless Access
- WAN links and services

## Local Area Networking Technology

- Ethernet Bus Architecture
- Broadcast in nature

## Wide Area Networking links and services

- Leased lines, SONET & RF
- ATM, Frame Relay and X.25

## Systems Networking Architecture

- Single Logical Network
- Star topology & Centralized processing
- Integration with LAN achieved by Terminal Emulation programs
- Integration with WAN possible by making SNA support over links and services

# SNA Connectivity

Centralized Processing – Star Topology

■ IBM host

Communications  
Controller – FEP  
IBM 3720/3745

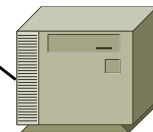
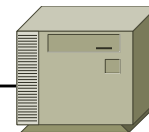
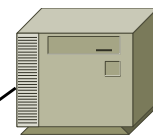
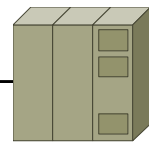
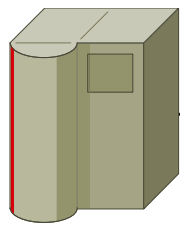

Cluster  
Controllers  
IBM 317X

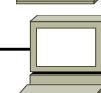
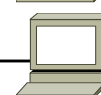
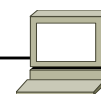
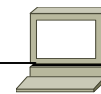
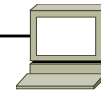
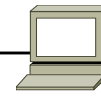

■ dumb terminals

■ hierarchical



# Bandwidth and High Speed Networking

In general, Bandwidth is considered to be the data transfer rate in terms of bits per second between the source and destination devices.

High speed networking involves Gigabit (1000 Megabit) per second rather than megabit per second

The factors effecting bandwidth are

- Physical connectivity, medium and the total data rate capacity
- The methods of sharing the bandwidth or media

In data communications bandwidth is normally in not guaranteed. It is plug and pray!

# Networks Services – Users' Perspective

## Access Networks

- Dial-up
- DSL/ADSL
- Cable Modem
- FiOS (fiber optics solution/fiber to the premises)

## Edge Networks

- Service Providers Access Points
- Connectivity among service providers

## Core Network

- Service providers main connectivity center
- Normally secured and fail-safe

## Network Services by Service Providers

- **communication infrastructure** enables distributed applications:
  - Web, email, games, e-commerce, database., voting, file and music (MP3) sharing
- **communication services provided to applications:**
  - connectionless
  - connection-oriented

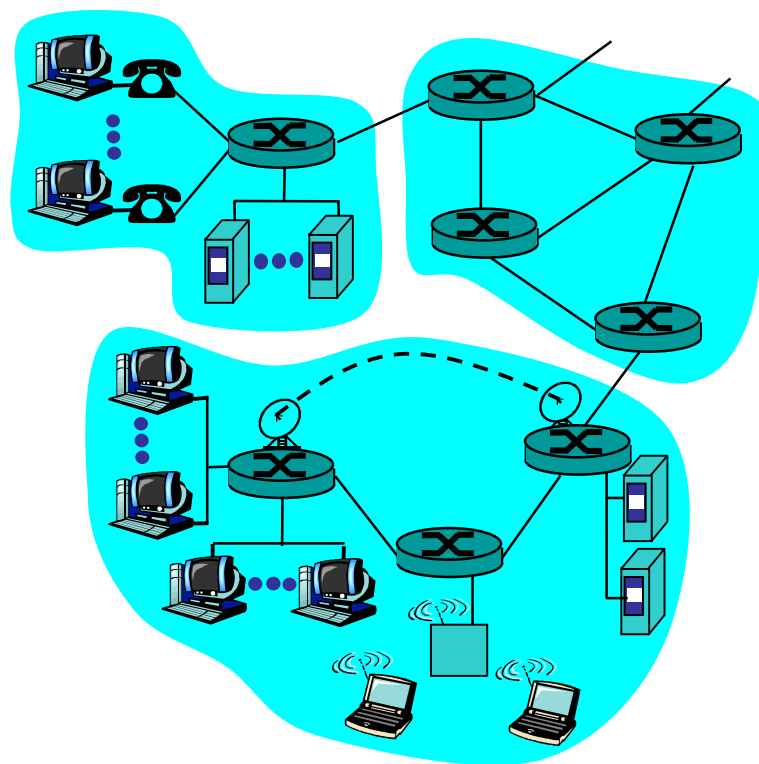

# Network Infrastructure

- **network edge:**  
applications and hosts
- **network core:**
  - High capacity routers
- **access networks, physical media:**  
communication links

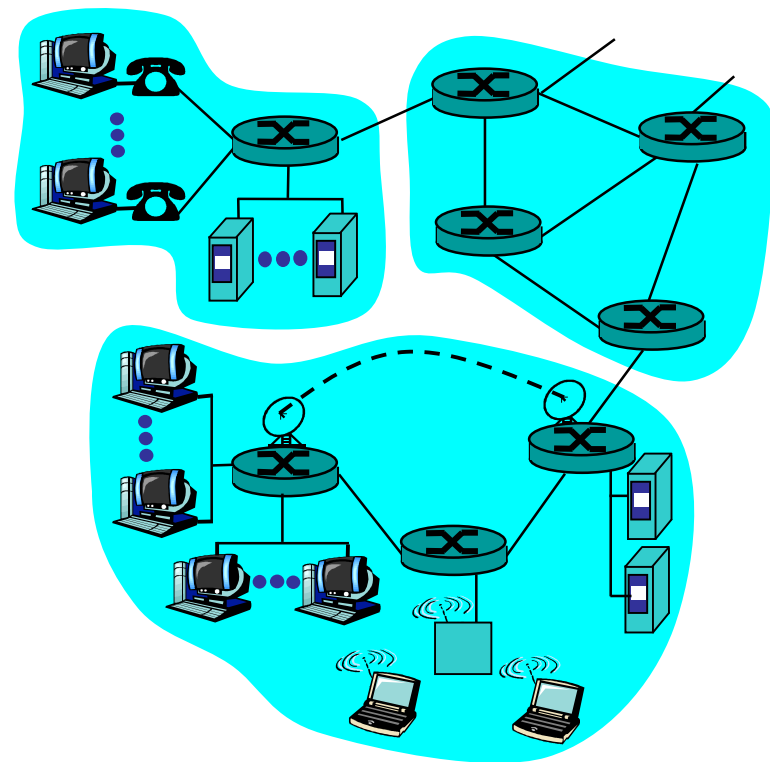

# Types of Networking Infrastructure

## Telephone Networks

- Creates circuits/lines on demand
- Dedicated for the duration of the call
- Fixed bandwidth
- Connection oriented
- Guaranteed delivery
- 99.999% reliable
- Low voltage -48V, safe against power failure

## Data Networks

- Always accessible but connectionless
- No dedicated bandwidth
- Statistically shared bandwidth
- No Guarantee for delivery
- Normally 99% reliable
- Based on regular power
- Standby power required against failure

A new type of networking infrastructure called MANET (Mobile and Ad-hoc Network) is being developed to carry data from sensors monitoring chemical and biological information

# The Converging Network

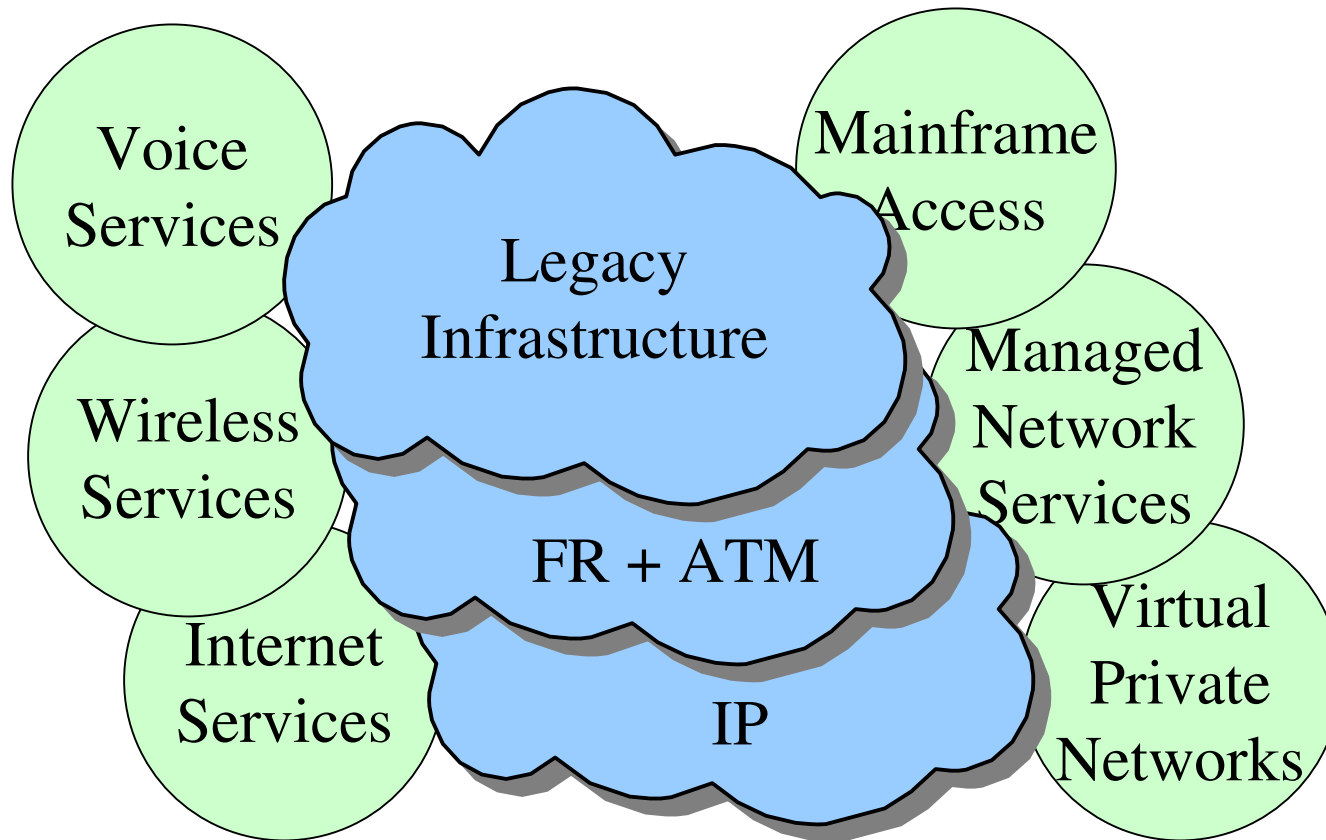

IP (Internet Protocol) is the heart of this convergence

# Intranet - Enterprise Networks

## Local Area Networks (LAN)

- Ethernet (linear bus topology)
- Token Ring (ring topology)
- FDDI (ring topology), fiber distributed data interface

## Metropolitan Area Networks (MAN)

- Connecting multiple LAN's
- No uniform topology

## Wide Area Networks (WAN)

- Defines Intranet
- Covers widespread geographic area
- Multiple countries and multiple cities could be connected

# Internet

- Networks of networks
- Accessible to general public
- No centralized control
- Loosely Hierarchical
- Best effort delivery
- No guaranteed bandwidth
- Very efficient and flexible
- Responsible for silent revolution in  
Communications Industry
- Brought the Information Age
- Enhanced Globalization for a new economic order

# Networking Elements

## Intelligent devices (Hardware)

- PC consisting of CPU and I/O
- Network Interface Card
- LAN Switches
- Routers

The Intelligent devices that we need for networking would not exist without the contribution from the Semiconductor industry.

## Network Operating Systems (software for Controlling Input & Output)

- Microsoft Windows
- Unix
- Apple Mac
- Linux

# Network Interface

- The gateway to the network from an Intelligent Device is NIC (Network Interface Card)
- It provides the electronic signal characteristics, Framing and bandwidth sharing mechanism
- The bandwidth allocations in LAN environment is Highly statistical in nature
- The broadcast nature of LAN algorithm is very flexible and efficient
- The LAN technology avoids cabling nightmare

## Mesh V. Broadcast Type of LAN

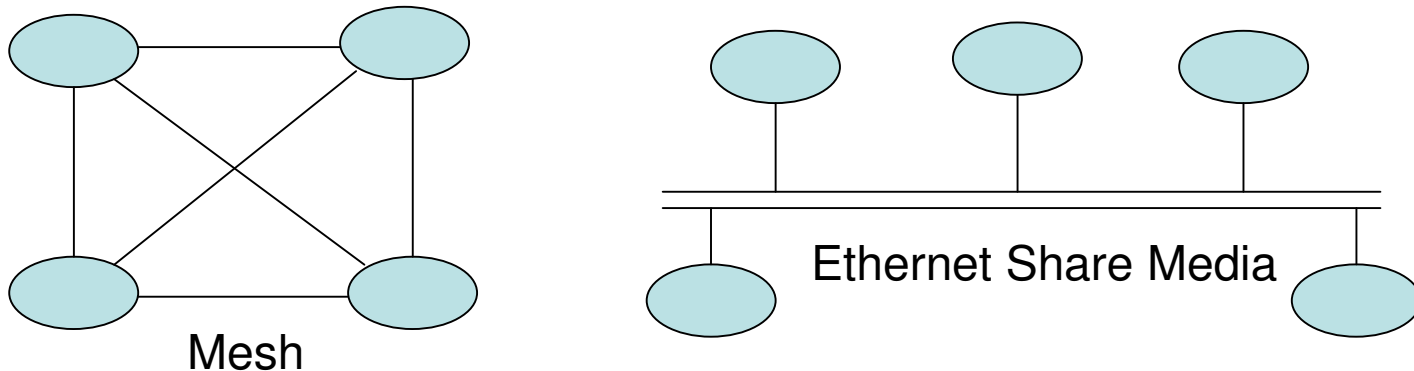

For a network of 4 devices you require 6 connections or links that can ensure guaranteed bandwidth and delivery. This is typically known as connection oriented environment.

For 100 devices you need  $100(99)/2=4,950$  links ( a nightmare!!)

Ethernet LAN technology would require a linear bus to be shared by numerous devices simplifying cabling and connectivity.

Ethernet has been evolved from 10 MB/s to 10 GB/s because of its simplicity

## Token Ring LAN Technology

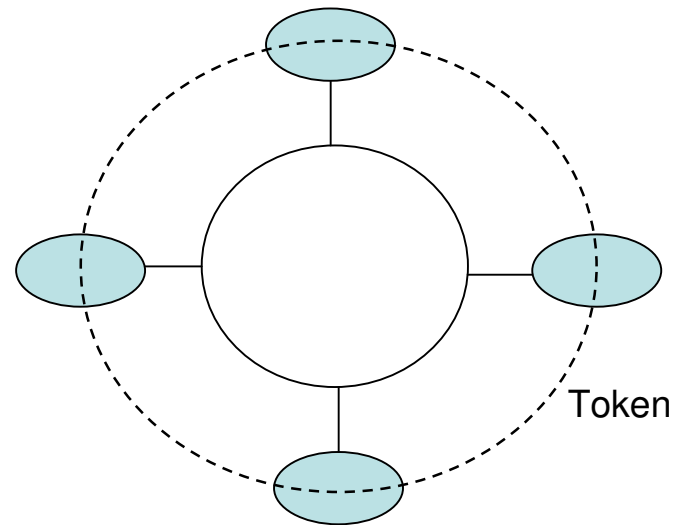

Token Ring is also broadcast type using an electronic token That is passed around.

It is more deterministic than Ethernet but relatively complex and expensive.

FDDI is fiber optics version of the Token Ring. The maximum Bandwidth available is 100 MB/s

## So where does the Semiconductor Industry Fit in?

Network Interface cards require appropriate Chip sets to implement Framing and signal characteristics.

No Ethernet chip sets no Ethernet NIC.

Framing is a process of creating a well defined block of digital bits with identifiable parameters that help complete the data transfer or communications.

Connectivity components e.g. LAN switches and routers require chip sets to implement switching and routing.

Broadband access devices e.g. ADSL Modem, Cable Modem and Fiber connectivity require special DSP chips. In addition other types of chips are needed to convert Ethernet frame to other appropriate format.

# Wide Area Networking Links

WAN Links are the most important components of the Networking Infrastructure because of the cost of the Long haul transmission lines.

There are two types of services available

- Fixed Bandwidth (circuit switched)
- SONET (Synchronous Optical Networks)
- Packet switched
  - Frame Relay
  - ATM
  - X.25

Fixed Bandwidth circuit switched T1/T3 services are also Known as Leased Line. Multiplexing is achieved by Time Division.

SONET is also fixed bandwidth of high order because it uses fiber optics technology

## Packet switching services

It is a method of sharing expensive long haul transmission on the basis of statistics.

Sharing is achieved by using the concept of Virtual Circuit.

These logical parameters are allocated to customers for identifying the data stream from respective customers.

These services are 4 to 5 times cheaper than corresponding Fixed bandwidth services.

This is a win-win situation since the customers do not have to pay as much as a fixed bandwidth services. The service providers can Oversubscribe their line generating much higher revenue than a Fixed bandwidth services.

## Packet Switching Services Detail

ATM can provide integrated services through its Quality of Services to support Voice, video and data over the same Link. You can have separate virtual circuits for different Services with different traffic characteristics.

Frame Relay does not have quality of service and hence used Primarily for data services.

X.25 is considered to be a legacy packet switching services. Very accurate and efficient for small chunk of data. Very widely Used in Credit Card verification system

To implement all the above you require the appropriate chip Sets. And there you go again!! – chips and more chips.

Packet Switching services can be implemented over any link.

# Fiber Optics Transmission

## SONET Standard

- Hierarchical and Simple multiplexing like Time Division
- Established standard
- Very accurate and stable long haul transmission
- Multiplexing is done electronically
- Requires numerous A/D and D/A conversions
- Requires Electrical to Optical and Optical to Electrical transducers.

Since Multiplexing is done in the hardware you need chips.

OC-1 is 51.84 MB/s and OC-768 is 40 GB/s

## Wave Division Multiplexing and Dense Wave Division Multiplexing

- To overcome the limitations SONET multiplexing WDM and DWDM can be utilized to achieve higher Bandwidth.

# Wireless LAN Access

The WiFi and Wimax Standards are here for wireless access to The Internet.

The sharing of the RF channels and sharing of the Ethernet linear bus are in accordance with IEEE 802.11 standards.

You need wireless network interface cards in your PC or Laptop. IEEE 802.11 is implemented by appropriate chips or chip sets.

WiMax is based on IEEE 802.16 standard. It requires RF towers and can be used to access service providers' access point Directly from home or office. Once again you need a different Set of chips.

# WAN Technologies Overview

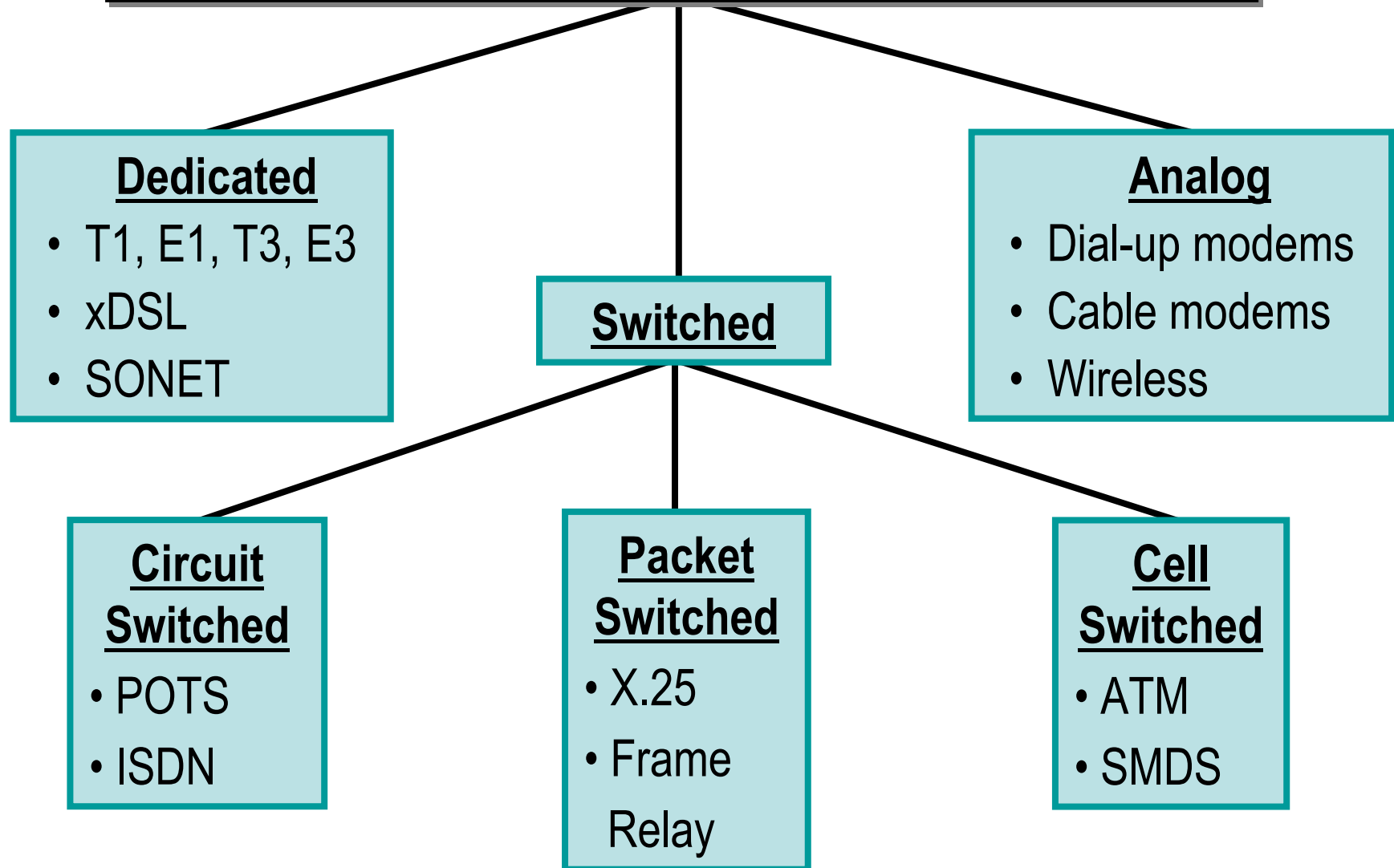

# Internet Connectivity

Internet connectivity is achieved by using routers. The main purpose of the routers is to segment broadcast Networks like Ethernet to restrict broadcast traffic to a single Logical network.

At the same time routers would forward IP packet to the correct Port depending on the destination address.

IP packet is well defined block of bits having logical addressing to establish host to host communications from anywhere to anywhere else.

The current version of addressing look like 192.1.2.3 which is In dotted decimal format. Internet is a routed Network.

The applications architecture is based on a family of Protocols known as TCP/IP

- **IP address:** 32-bit identifier for host, router *interface*
- ***interface:*** connection between host/router and physical link
  - router's typically have multiple interfaces
  - host may have multiple interfaces
  - IP addresses associated with each interface

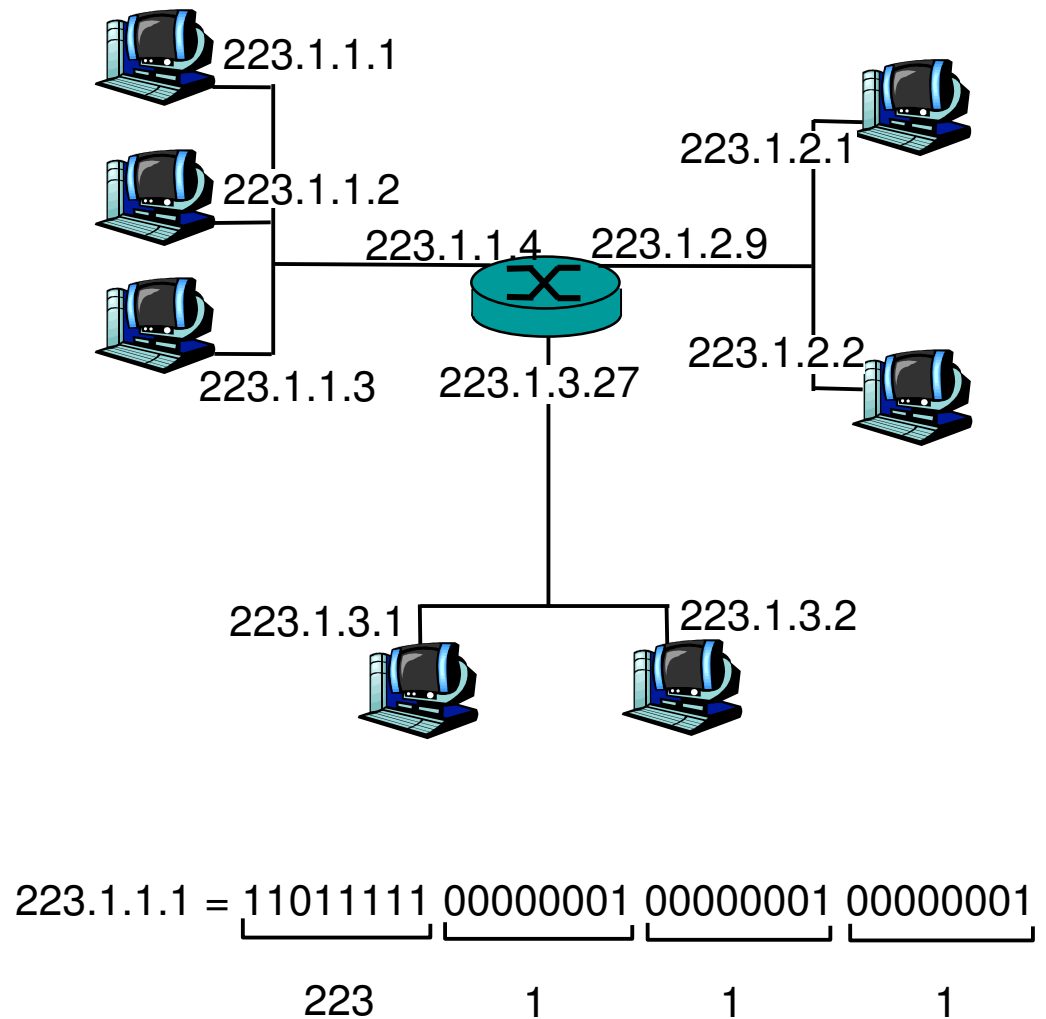

- IP address:
  - network part (high order bits)
  - host part (low order bits)
- *What's a network ?*  
(from IP address perspective)
  - device interfaces with same network part of IP address
  - can physically reach each other without intervening router

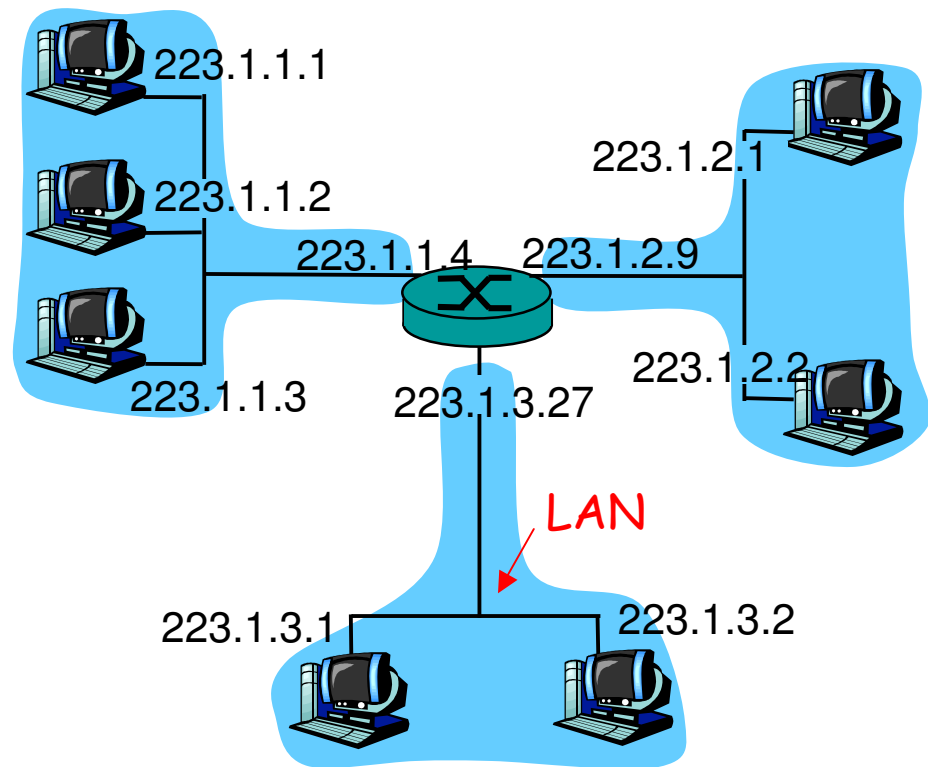

network consisting of 3 IP networks  
(for IP addresses starting with 223,  
first 24 bits are network address)

# IP addresses: how to get one?

Q: How does *host* get IP address?

- hard-coded by system admin in a file
  - Wintel: control-panel->network->configuration->tcp/ip->properties
  - UNIX: /etc/rc.config
- **DHCP: Dynamic Host Configuration Protocol:** dynamically get address from as server
  - “plug-and-play”(more shortly)

# IP addresses: how to get one?

Q: How does *network* get network part of IP addr?

A: gets allocated portion of its provider ISP's address space

ISP's block	<u>11001000 00010111 00010000</u>	00000000	200.23.16.0/20
Organization 0	<u>11001000 00010111 00010000</u>	00000000	200.23.16.0/23
Organization 1	<u>11001000 00010111 00010010</u>	00000000	200.23.18.0/23
Organization 2	<u>11001000 00010111 00010100</u>	00000000	200.23.20.0/23
...	.....	....	....
Organization 7	<u>11001000 00010111 00011110</u>	00000000	200.23.30.0/23

Hierarchical addressing allows efficient advertisement of routing information:

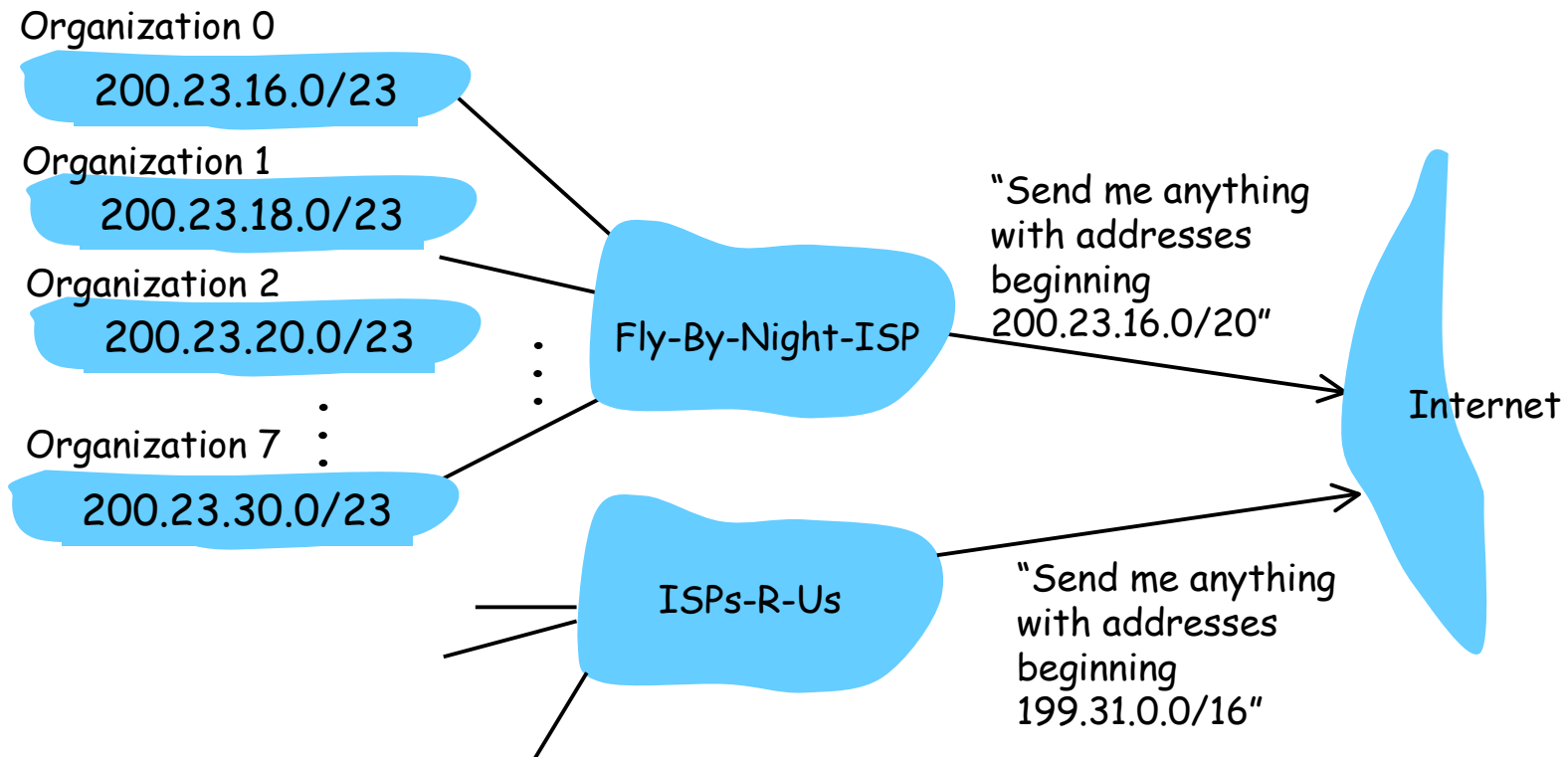

# Hierarchical addressing: more specific routes

ISPs-R-Us has a more specific route to Organization 1

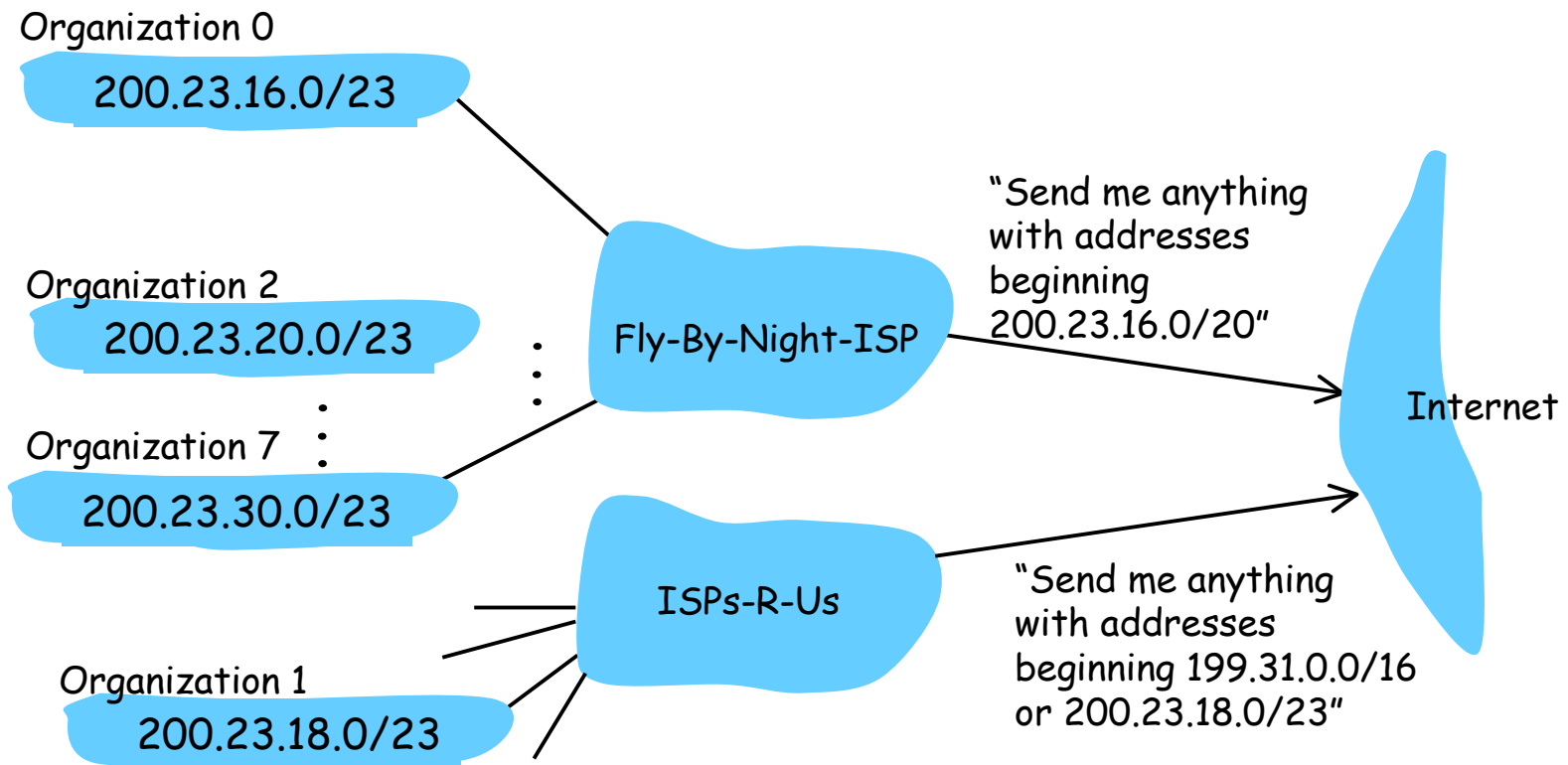

# IP addressing: the last word...

Q: How does an ISP get block of addresses?

A: **ICANN**: Internet **C**orporation for **A**ssigned **N**ames and **N**umbers

- allocates addresses
- manages DNS
- assigns domain names, resolves disputes

# Routing in the Internet

- The Global Internet consists of **Autonomous Systems (AS)** interconnected with each other:
  - **Stub AS**: small corporation: one connection to other AS's
  - **Multihomed AS**: large corporation (no transit): multiple connections to other AS's
  - **Transit AS**: provider, hooking many AS's together
- Two-level routing:
  - **Intra-AS**: administrator responsible for choice of routing algorithm within network
  - **Inter-AS**: unique standard for inter-AS routing: BGP

# Internet AS Hierarchy

Intra-AS border (exterior gateway) routers

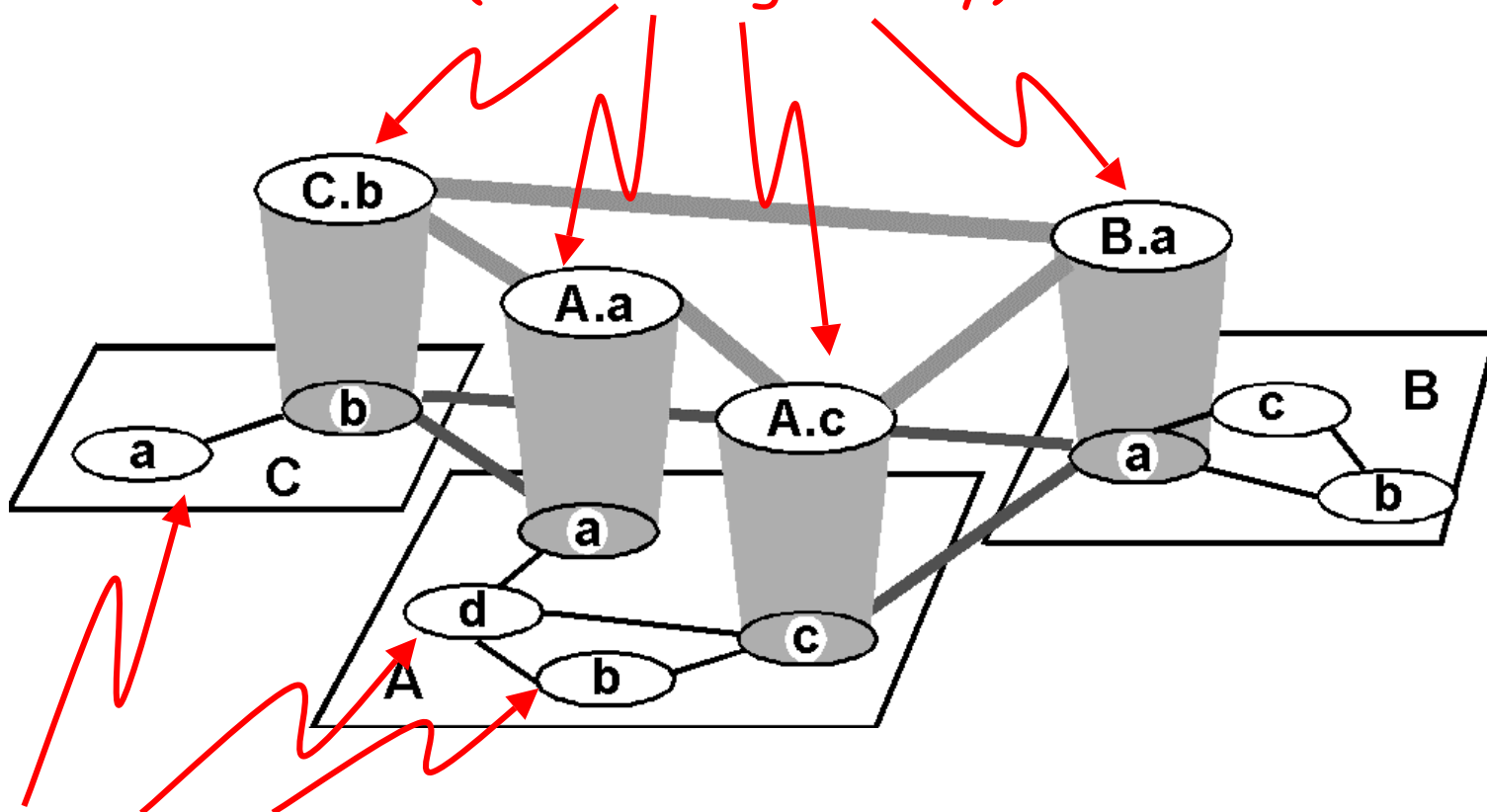

Inter-AS interior (gateway) routers

# Intra-AS Routing

- Also known as **Interior Gateway Protocols (IGP)**
- Most common Intra-AS routing protocols:
  - RIP: Routing Information Protocol
  - OSPF: Open Shortest Path First
  - IGRP: Interior Gateway Routing Protocol (Cisco proprietary)

# Inter-AS routing in the Internet: BGP

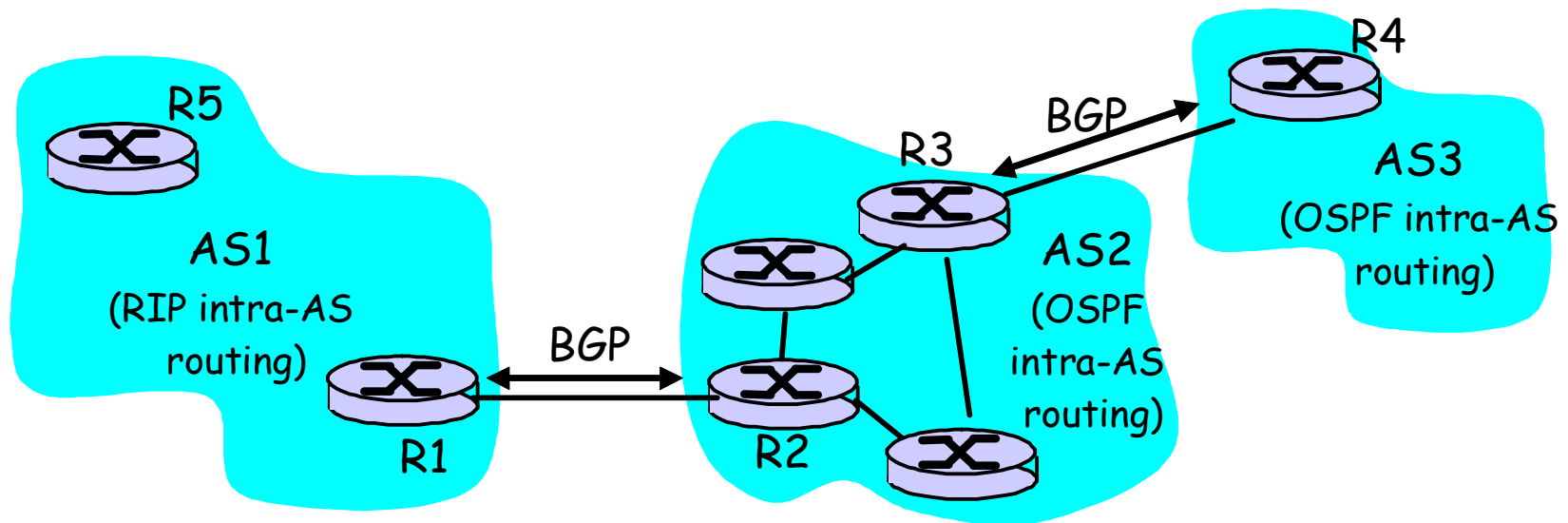

# BGP operation

## Q: What does a BGP router do?

- Receiving and filtering route advertisements from directly attached neighbor(s).
- Route selection.
  - To route to destination X, which path (of several advertised) will be taken?
- Sending route advertisements to neighbors.

# Router Architecture Overview

Two key router functions:

- run routing algorithms/protocol (RIP, OSPF, BGP)

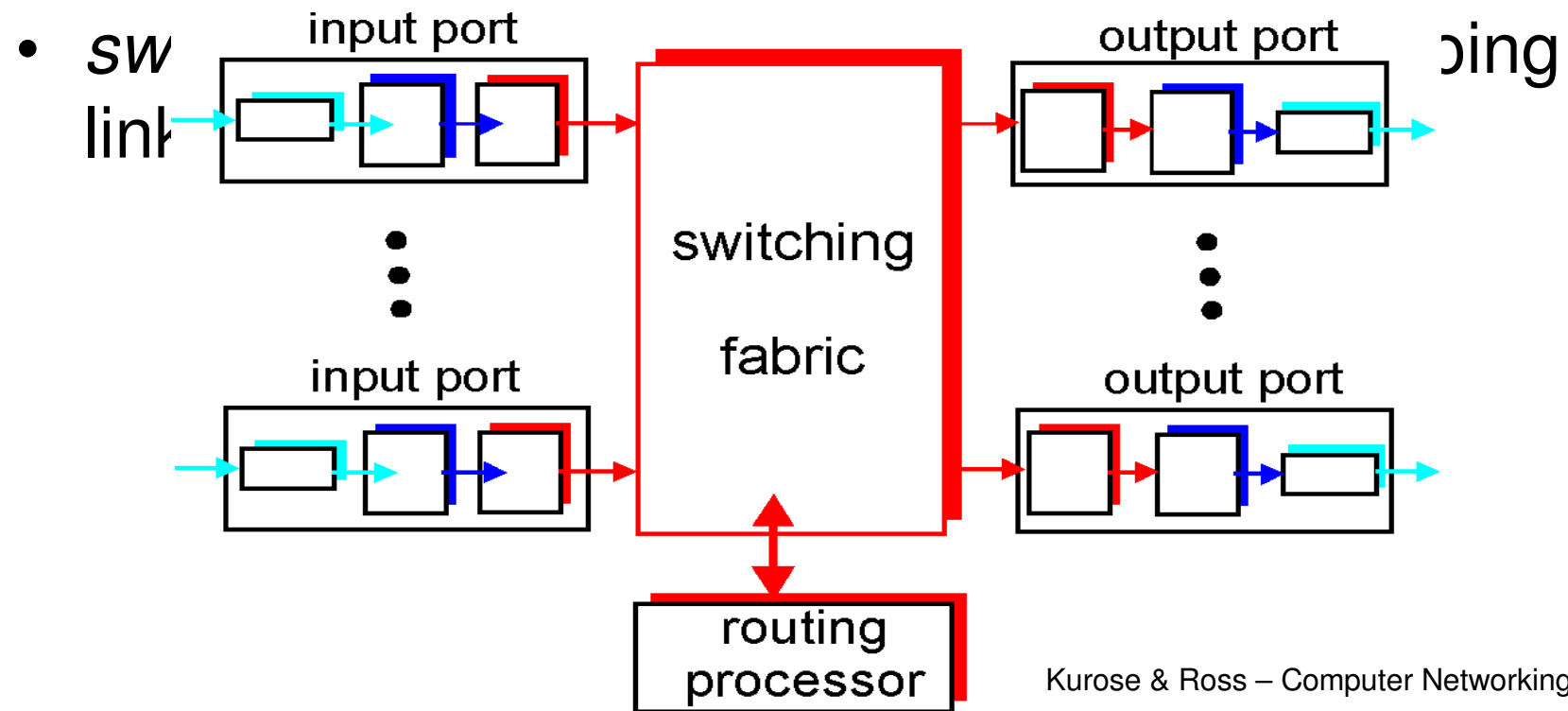

# Single Networking Infrastructure

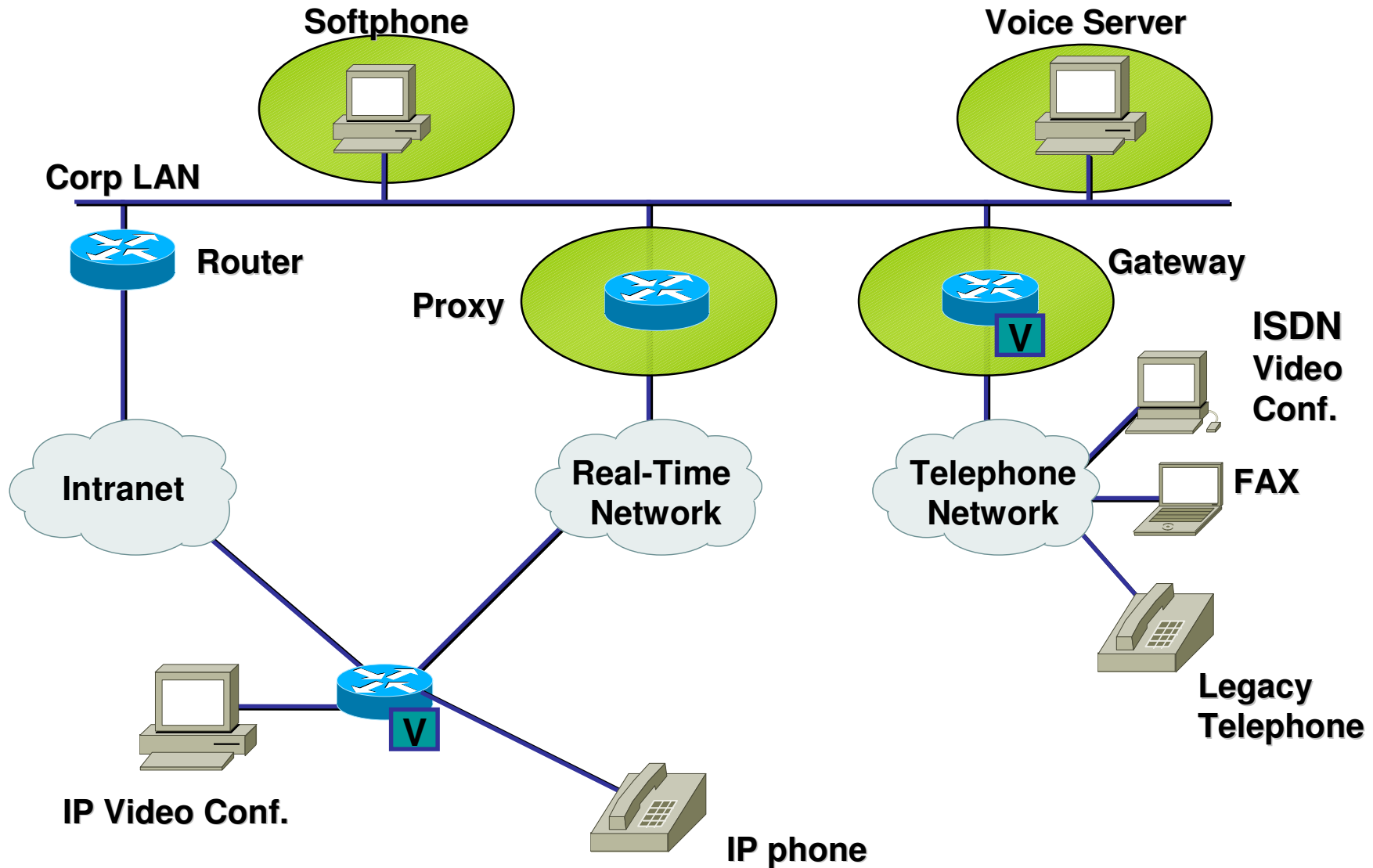

# IP Telephony

There are three styles of **Voice over IP** calls:

- ✓ PC to PC
- ✓ PC to Phone
- ✓ Phone to Phone

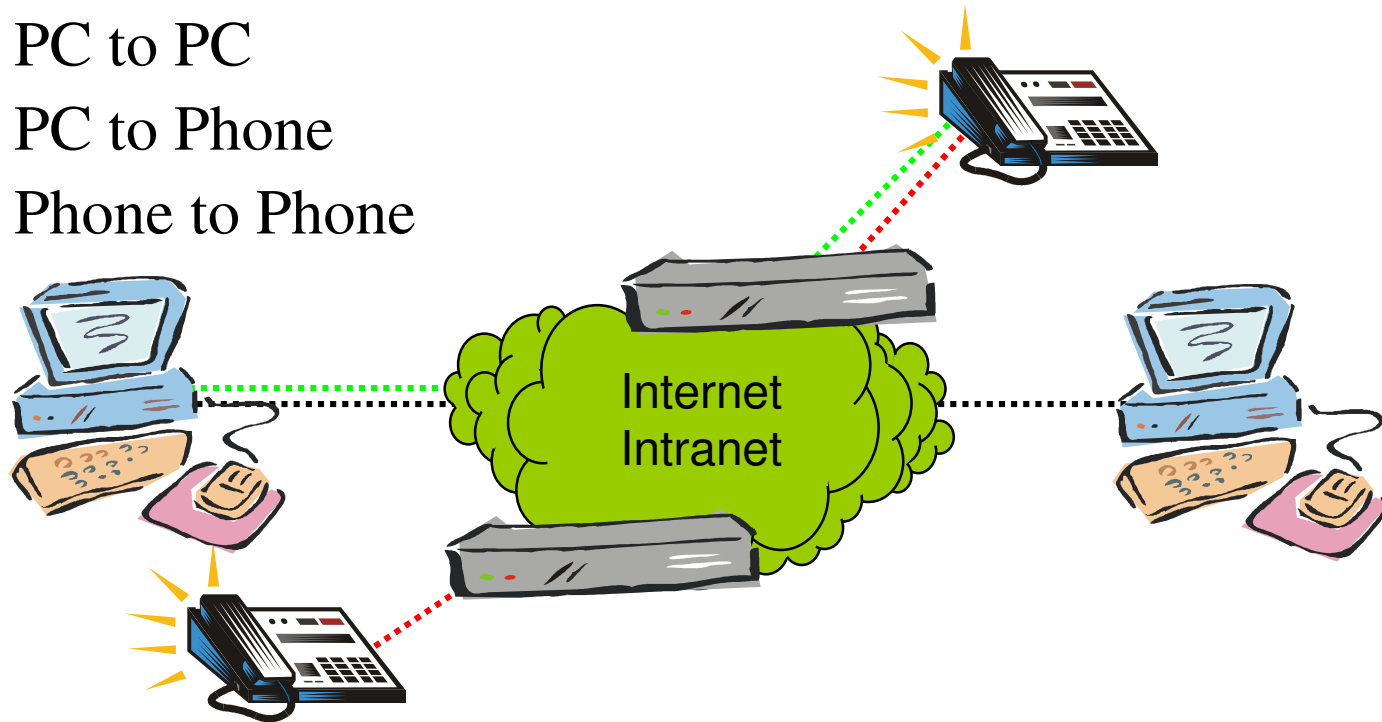

✓ **Gateways** adapt traditional telephony to the Internet

## Use of DSP in IP Telephony

- A series of processors perform the adaptation from **Traditional** to **Internet Telephony**

Digital Signal Processor(s) (**DSP**)

Voice Compression  
Tone Detection/Generation  
Echo Cancellation  
Silence Suppression

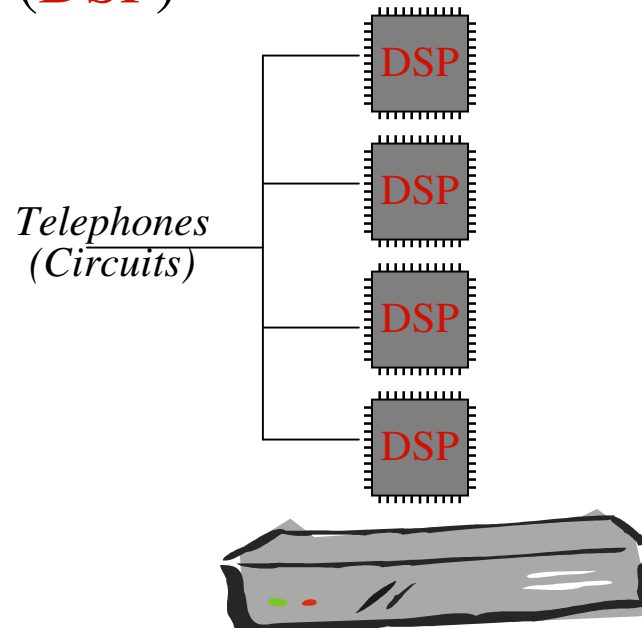

## IP Telephony Details

- ✓ **Echo** is removed
- ✓ Voice Activity Detector (**VAD**) removes silence \*
- ✓ **Tone Detection** is performed
  - ✓ detected signaling tones are routed around the CODEC. Most CODECs garble signaling tones to the point that they are unrecognizable by the devices they are intended for

# CODEC in IP Telephony

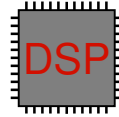

- ✓ The PCM stream is fed into the **CODEC**

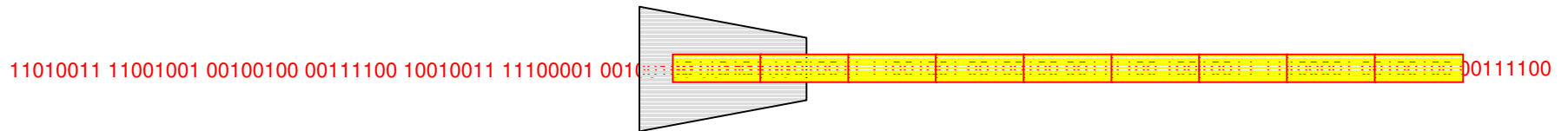

- ✓ And Voice frames are created
  - ✓ Most CODECs also compress the PCM stream
    - ✓ PCM **G.711** generates 64,000 bits per second
    - ✓ **G.729a** compression generates 8,000 bits per second
- ✓ Each Frame is 10 ms long (G.729a) and contains 10 bytes of “speech”



# RTP Implementation in IP Telephony

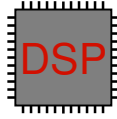

- ✓ Packet Assembler Software within the DSP takes frames from the CODEC and creates Packets
- ✓ Several frames may be combined in a single packet

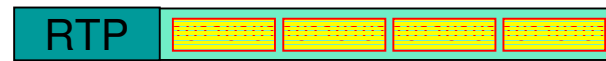

- ✓ A 12 byte Real Time Protocol (**RTP**) Header is added
  - ✓ Provides sequence number
  - ✓ Time stamp
- ✓ The packet is forwarded to the gateway's host processor

# IP Addressing in IP Telephony

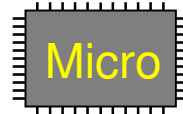

- ✓ Dialed digits identified by the tone detection performed in the DSP are used to determine the **destination number**

***301-999-1212 = 192.128.100.2***

- ✓ This number is mapped to an **IP Address**
- ✓ A 20 byte **IP header** is added to the packet containing:
  - ✓ The IP address of this gateway (the source address)
  - ✓ The IP address of the destination gateway
- ✓ An 8 byte **UDP** header containing source and destination sockets is also added

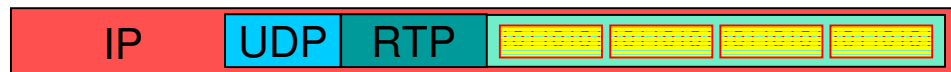

# IP Addressing and Routing in the Internet

- ✓ **Routers** and **Switches** in the Internet examine the addresses in the IP address in order to identify the route to the destination

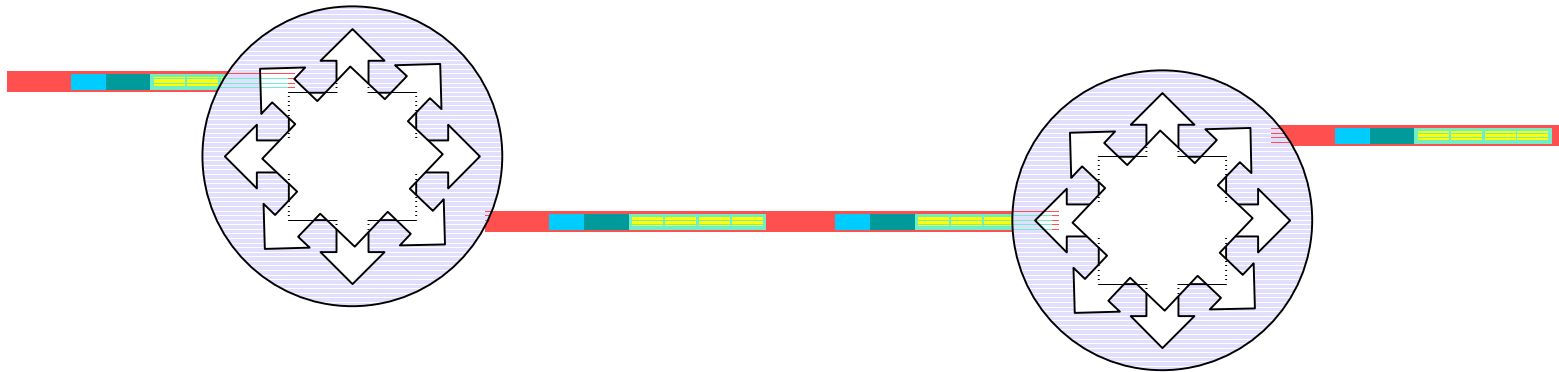

- ✓ Several Routers and or switches may be in the path that the packets take to their destination

## Conclusion

The next generation high speed networks would heavily depend on the semiconductor industry for bandwidth and performance.

The router performance would depend on High performance CPU that can process millions of IP packets per second. Improved ASIC could enhance performance even further.

The bandwidth of LAN technology would depend on high performance and reliable chip sets.

WAN link and Long haul transmission cost could come down by having a enhanced electrical to optical and optical to electrical transducers.

High performance A/D and D/A converters could enhance fiber optics transmission to a great extent.